



# INSTRUCTION BULLETIN

No. 9014056  
Machine: S20 Gas/LP  
S20 Diesel  
Published: 12-2015  
Rev. 02

**NOTE: DO NOT DISCARD the Parts List from the Instruction Bulletin. Place the Parts List in the appropriate place in the machine manual for future reference. Retaining the Parts List will make it easier to reorder individual parts and will save the cost of ordering an entire kit.**

*NOTE: Numbers in parenthesis ( ) are reference numbers for parts listed in Bill of Materials.*

Installation instructions for **kit number 9014034**

## SYNOPSIS:

This kit contains the parts needed to install a telemetry kit on S20 Gas/LP and Diesel sweepers. Please follow step-by-step instructions.

## SPECIAL TOOLS / CONSIDERATIONS: NONE

(Estimated time to complete: 1 hour)

**The IRIS (telemetry module) must be activated to complete this installation. The module will not function until it is activated. Call for assistance (North America - Technical Support / Australia - CCC) activating the module after all telemetry components have been installed. Have machine serial number and IRIS module SIM number (located on back of IRIS control box assembly) ready when calling for activation.**

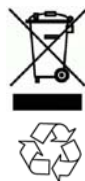

## PROTECT THE ENVIRONMENT

Please dispose of packaging materials, used machine components such as batteries and fluids in an environmentally safe way according to local waste disposal regulations.

Always remember to recycle.

## PREPARATION:

1. Start machine. Observe the panel display for fault / diagnostic codes. All fault / diagnostic codes must be corrected before the IRIS system can be installed onto the machine.

**FOR SAFETY: Before leaving or servicing machine, stop on level surface, turn off machine, set parking brake, and remove key.**

## INSTALLATION:

2. Lift the hopper cover open and engage the support to keep the hopper in the raised position.
3. Drill two 1/8 in. (3.1750 mm) holes through the inner surface of the front shroud. **Do Not** drill into the front surface of the front shroud.

4. Use two pan screws (2) and two cable clamps (4) to install the antenna (3) onto the front shroud. (Fig. 1 / Fig. 2)

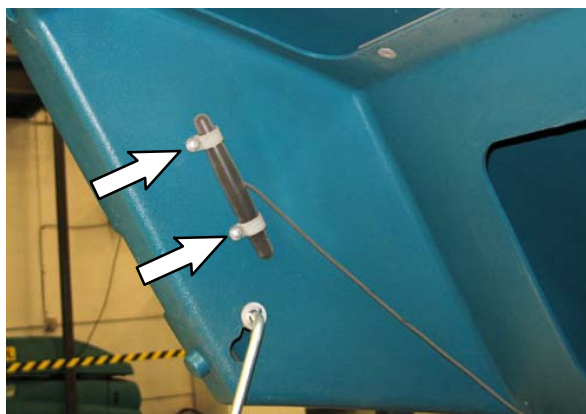
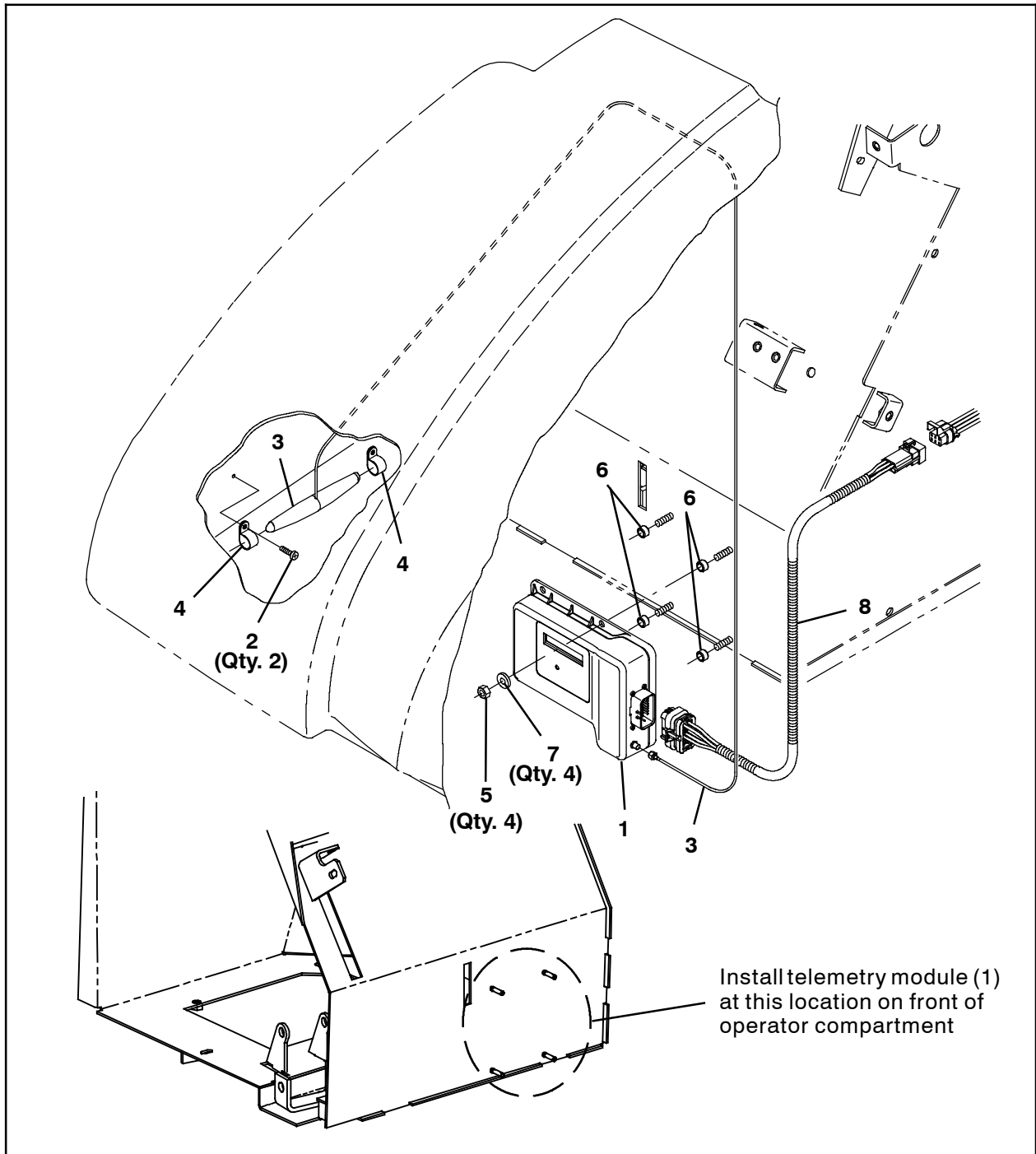

FIG. 1



**FIG. 2**

5. Start the machine, completely raise the hopper, engage the hopper support bar, and turn off the machine.

**WARNING:** Raised hopper may fall. Engage hopper support bar.

6. Lift the main cover open and lock the main cover into the open position.

7. Disconnect the battery cables from the batteries.

**WARNING:** Always disconnect battery cables from machine before working on electrical components.

- Remove the additional SIM label from the back of the control box (1) and set label aside in a safe place. The number on the SIM label will be needed for activating the machine. (Fig. 3)

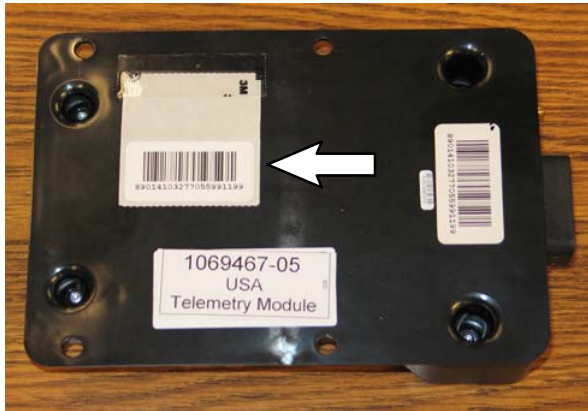

FIG. 3

- Use four M6 hex nuts (5), four flat washers (7), and four sleeves (6) to install the telemetry module (1) onto the front of the operator compartment. (Fig. 2)
- Connect the antenna (3) cable to the telemetry module (1). (Fig. 2 / Fig. 4)
- Connect the telemetry harness (8) to the telemetry module (1). (Fig. 2 / Fig. 4)
- Route the telemetry harness (8) into the engine compartment and connect the telemetry harness to the main wire harness. (Fig. 2 / Fig. 4)

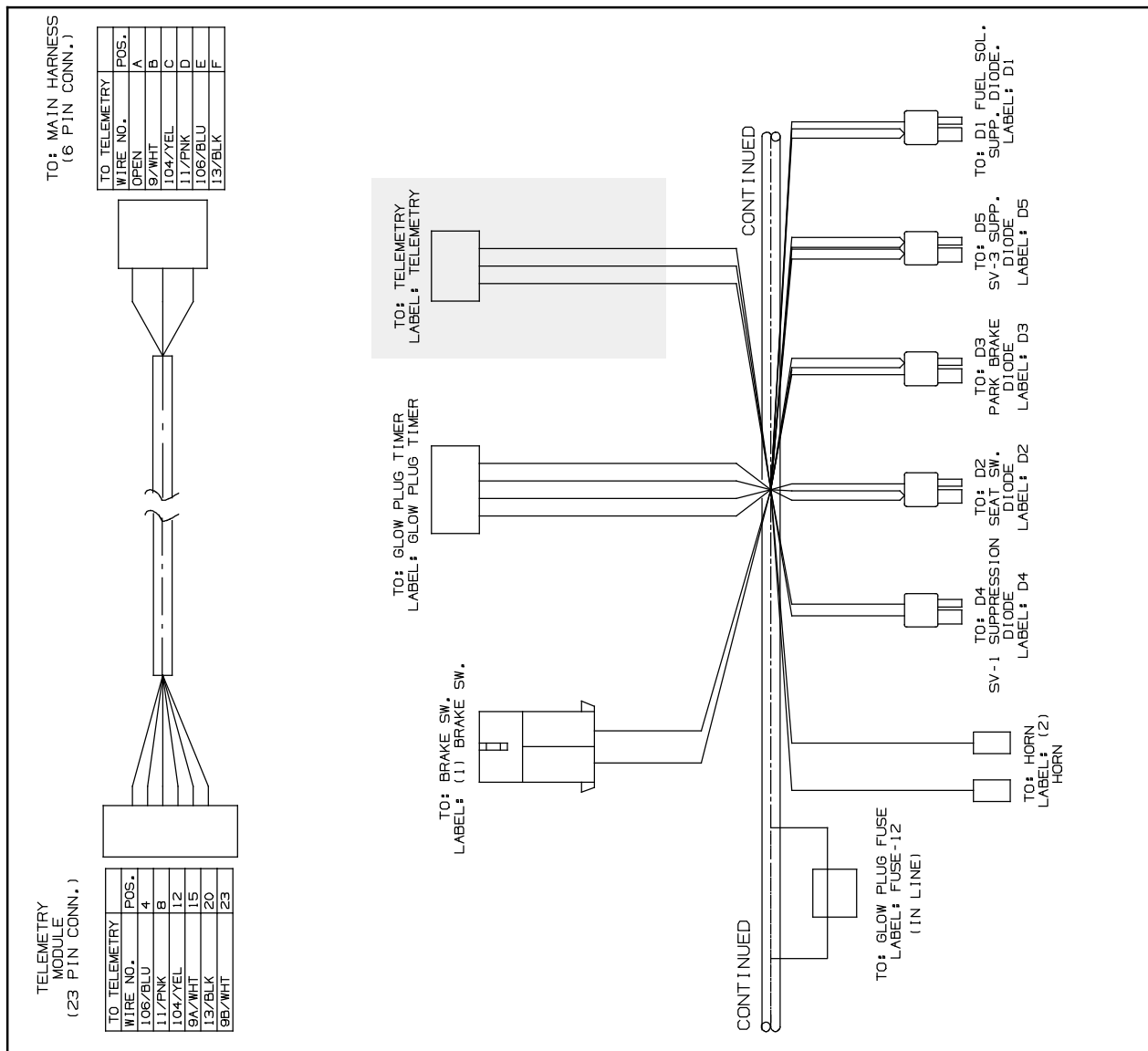

FIG. 4

13. Remove the cover from the fuse box. (Fig. 5)



FIG. 5

14. Plug the 15-Amp fuse (9) into fuse box location 11. (Fig. 6)

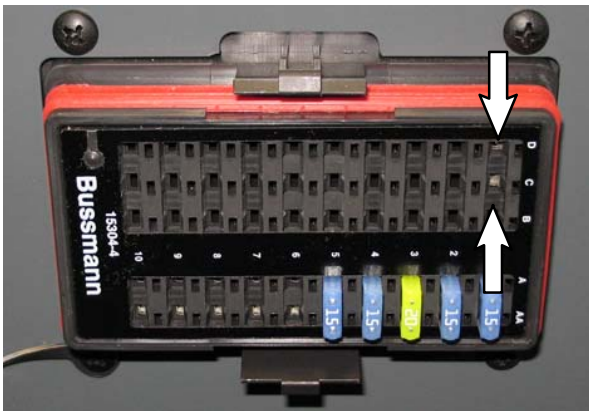

FIG. 6

15. Reinstall the cover onto the fuse box.

16. Reconnect the battery cables to the battery.

17. Start and test the machine.

18. **North America Customer Locations:** Activate the IRIS (telemetry module): Call Technical Support (between hours of 7:00 am and 5:00 pm CST) for assistance to activate the module. The IRIS telemetry system must be activated to complete this install. Have machine serial number and IRIS module SIM number ready when calling for activation.

19. **Australia Customer Locations:** Activate the IRIS (telemetry module): Call CCC (between hours of 8:00 am and 5:00 pm AEST) and ask to be routed to the IRIS expert for assistance to activate the module. The IRIS telemetry system must be activated to complete this install. Have machine serial number and IRIS module SIM number ready when calling for activation.

*NOTE: The IRIS (telemetry module) must be activated to complete this installation. The module will not function until it is activated. Call for assistance activating the module after all telemetry components have been installed.*

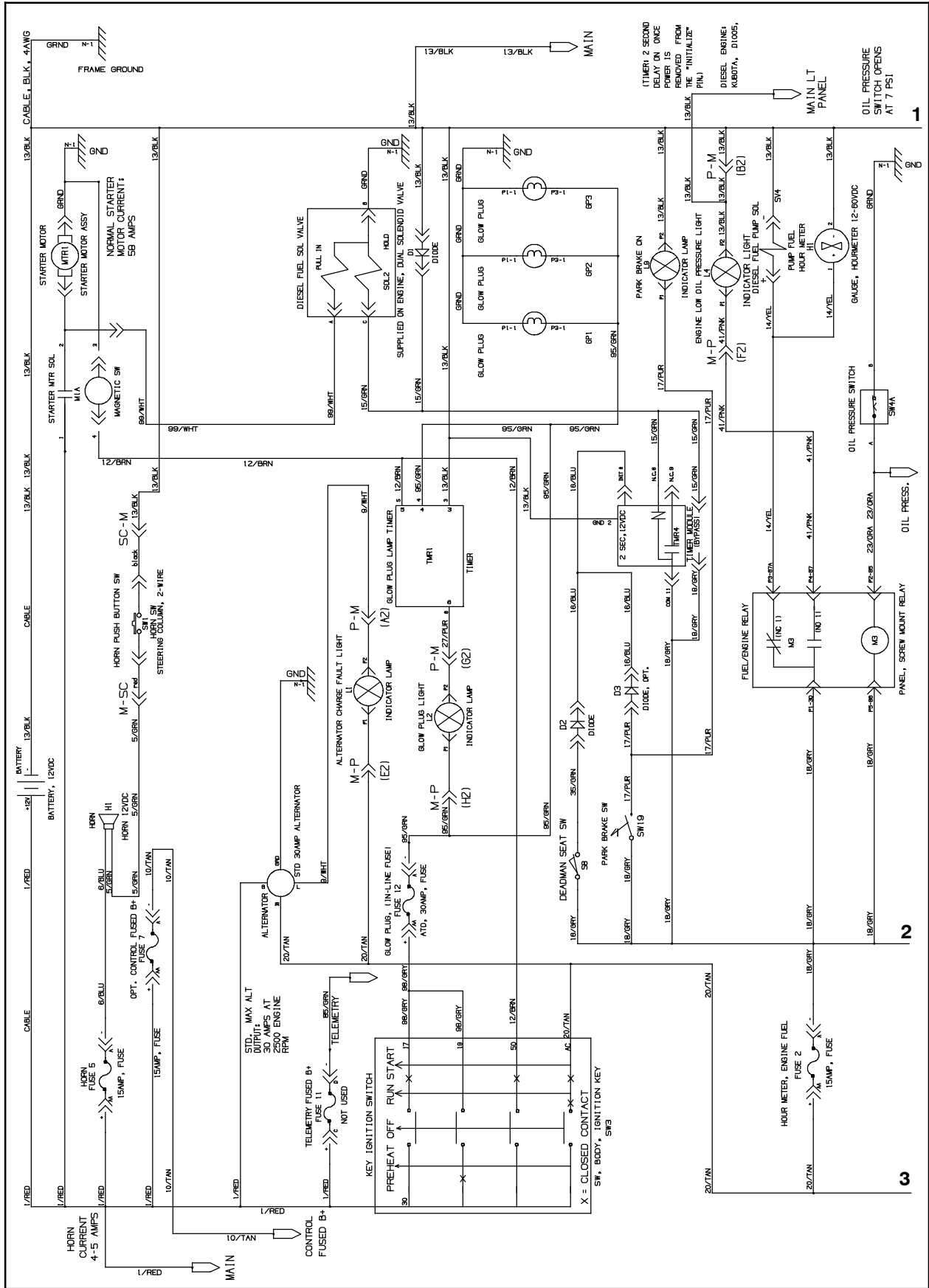

FIG. 7



---

**Bill Of Materials For Telemetry Kit, CI [S20, USA] - 9014034**

<b>Ref.</b>	<b>Tennant Part No.</b>	<b>Description</b>	<b>Qty.</b>
1	1069467	Control Box Assy Kit, Replmt, Telem[USA]	1
2	382320	Screw, Pan, Phl, 12- 16 X 0.50, F/ Plstc	2
3	1070324	Antenna, Telem, 110 In [GPRS]	1
4	140916	Clamp, Cable, Nyl, 0.62d, Nat	2
5	08708	Nut, Hex, Lock, M6 X 1.00, NI	4
6	222516	Sleeve, P/M, 0.32b 0.50d 0.3l [430ss]	4
7	32483	Washer, Flat, 0.25, SAE	4
8	1071132	Harness, Ele [Extn, Telemetry]	1
9	1030985	Fuse, Blade, 015a, 32vdc [Mini]	1

TENNANT COMPANY  
P. O. Box 1452  
Minneapolis, MN 55440-1452